

ITEM	QTY.	DESCRIPTION	FUNCTION
A	1	8"-150# LAP JOINT C/S FLG. W/ SCH. 80 C/S ASA LAP JOINT STUB END x 8"LG. W/ 316L S/S DIFFUSER W/ 316L S/S BLIND.	FEED WATER
B	1	8"-150# F.F.S.O. C/S FLG. W/ SCH. 40 316L S/S E.R.W. PIPE x 3 1/2"LG. W/ SCH. 40 90°-L.R. 316L S/S ELL. W/ SCH. 80 SMLS. SA-312-316L PIPE x 16 3/4"LG. W/ .1875"THK. x 11 1/2"O.D. C/S PAD W/ 8"-150# F.F.S.O. 316L S/S FLG. W/ 2"-3000# 316L S/S HALF CPLG.	TREATED WATER
C	1	4"-150# R.F.S.O. C/S FLG. W/ SCH. 80 316L S/S SMLS. PIPE x 5 5/16"LG.	MEDIA REMOVAL
D	1	4"-150# R.F.S.O. C/S FLG. W/ SCH. 80 C/S PIPE x 9"LG.	MEDIA FILL
E	1	1"-3000# 316L S/S FULL CPLG.	AIR RELEASE/VAC.
F	1	30" T-BOLT CLOSURE ASSEMBLY W/ DAVIT PER: SHT-1094-C & SHT-1096-C W/ .337"THK. x 44"O.D. SA-455 PAD	MANHOLE
G	1	14"x 18" M. WAY W/ 1 1/4"x 4"LG. SA-516-70 RING	MANHOLE
H	2	3/4"-3000# 316L S/S FULL CPLG.	SAMPLE
J	1	2"-150# R.F.S.O. C/S FLG. W/ SCH. 80 C/S PIPE x 9 1/2"LG.	COMPRESSED AIR
K	1	3"-150# R.F.S.O. C/S FLG. W/ SCH. 80 C/S PIPE x 13"LG.	RUPTURE DISK

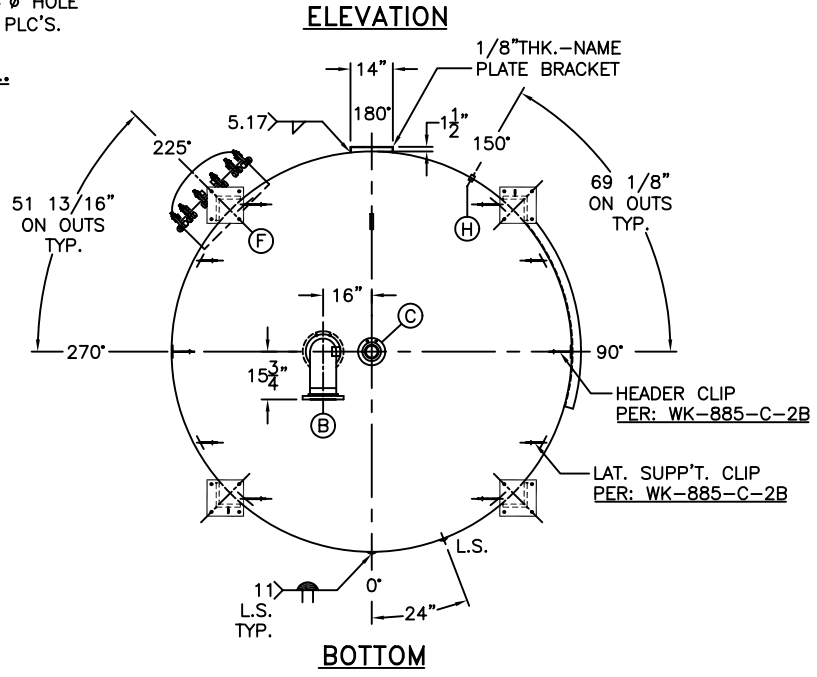
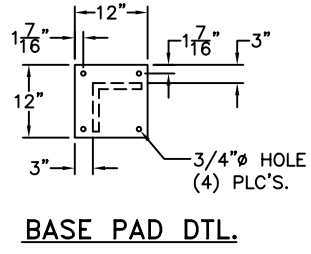
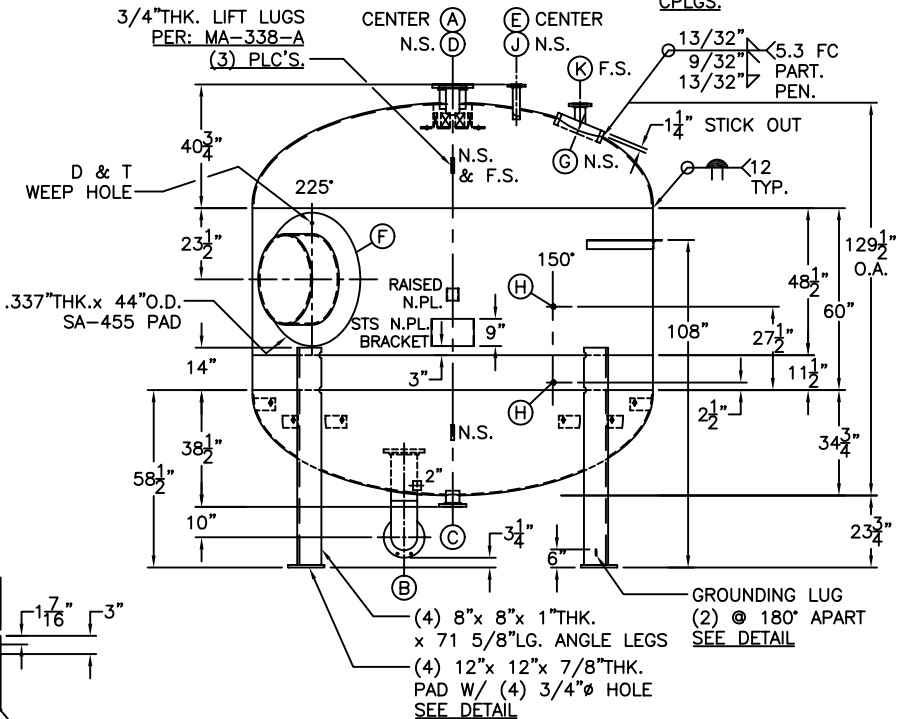
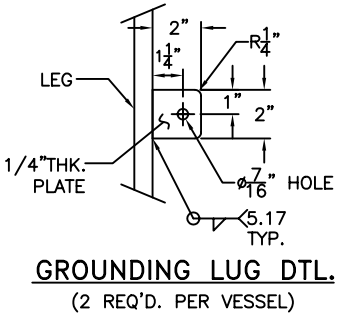
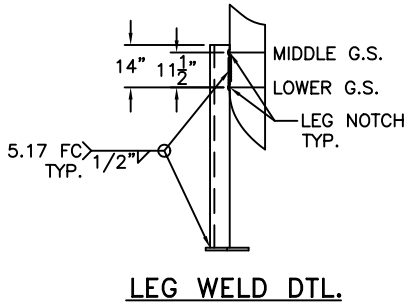
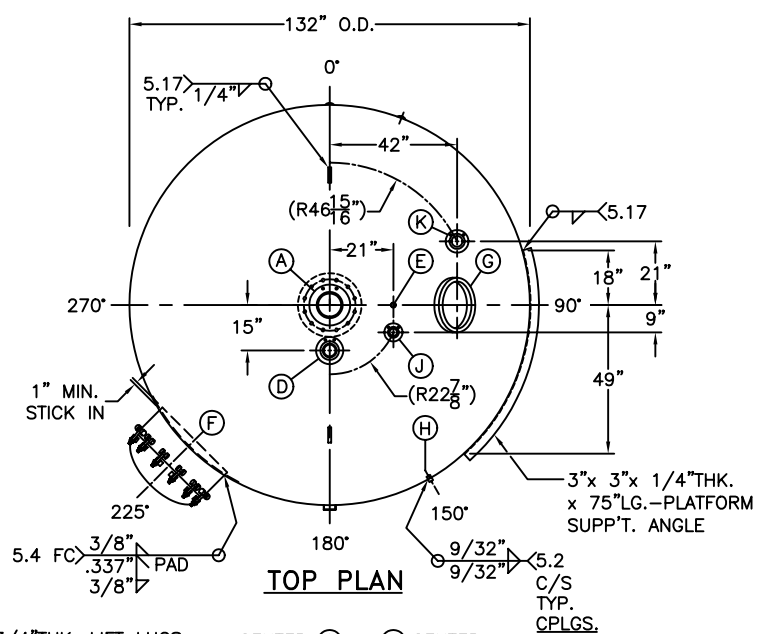

NOTE: 1) HYDRO @ 137 PSIG. MIN. 2) NOZZLE DETAILS PER: WK-885-C-1B. 3) HEADER LAT. & PIPE SUPP'T. CLIPS PER: WK-885-C-2B. 4) LATERAL SUPP'T. ANGLES PER: WK-885-C-3B. 5) LEFT HAND TANK. 6) UG-20(1) 7) UW-11(6)(5)(b)

SHELL / HEADS	
TOP-4375" SA-516-70-SEAMLESS 2:1 S.E. (.380" MIN.)	
BTM-375" SA-455-SPICED (.342" MIN.)	
375" SA-455	
M.A.W.P. 100 PSIG. @ 125 °F	
M.D.M.T. -20 °F @ 100 PSIG	
ASME SECTION VIII DIV. 1, 2001 ADD 2003	
X-RAY: RT-2 FULL L.S., SPOT G.S.	
GALLONS: 6422	
WT: 10823 LBS.	
SERIAL NO.	
N.B.	

FOR: WK-885-C	
VERT. WATER TANK	REV. 4-26-05
SURFACE AREA = 441.7 SQ. FT.	DATE: 11-3-04
INSIDE: TNEC SERIES 20	
POTAPOX 15-17 MILLS	
OUTSIDE: TNEC SERIES 27 FC	
TYPICAL 8-10 MILLS	
LEG-ZONE 2B-15 KM.	
BY: E.S. / BILL SCALE: 3/8"=12"	
ROY E. HANSON JR. MFG.	
1924 COMPTON AVE.	
LOS ANGELES, CA 90011	